

Compact Ironer

# Presstige™

**CHICAGO®**



## Large Diameter Roll Compact Ironer For Table Linen and Pillowcases

Presstige™ is Chicago's newest ironer innovation. Featuring a 32" (800mm) diameter ironing roll and a 62" (1550mm) wide ironing surface with return to front or rear, the Presstige is ideal for ironing 2 or 3 lanes of napkins or pillowcases or one lane of table tops.

The space saving Presstige is also perfect for use in laundries with limited floor space either as the primary ironer or as a second ironer for processing small pieces in laundries that have a full width ironer to handle sheets. Dual compression rolls for greater linen stretch, extra moisture removal, and finer quality finish.

# Presstige

## Dimensions and Utilities

### NOTE:

1. Specifications subject to change without notice. Consult factory for certified construction floorplan.
2. Millimeter dimensions are in [ ].
3. All dimensions are +/- 1/2".
4. Utility connections are located at rear.

CONNECTION(S)	DIA.	HEIGHT
(A) Air Connection	3/8"	5"[127]
(D) Air Drain	1/4"	5"[127]
(S) Steam Connection	2"	34"[864]
(C) Condensate Return	1"	11-1/2"[292]
(E) Electrical Connection	-	63-1/2"[1613]

Side View

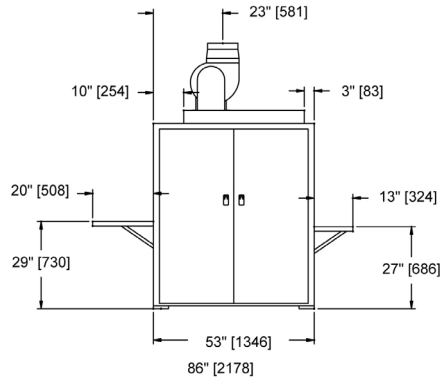

Top View

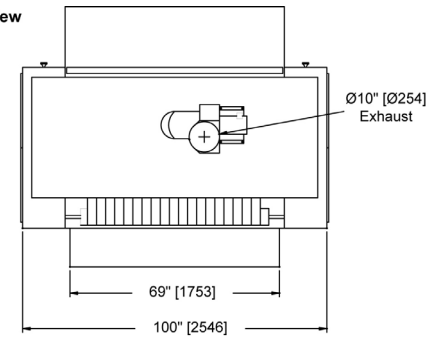

Front View

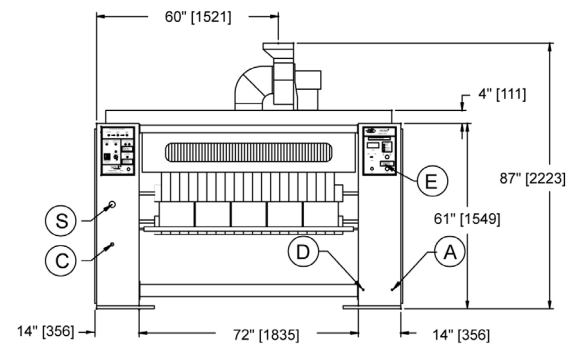

## Features

### Gas Heated Models:

- Streamlined power burner
- Touch control AC frequency inverter variable speed drive
- Patented touchless Eagle Eye temperature sensor for maximum moisture evaporation with minimum maintenance requirements

### Steam Heated Models:

- ASME inspected and certified steam heated cylinder
- Steam separator
- All needed traps, bypasses, and internal piping

## Optional Equipment

If multi-lane accumulation of small pieces is required, consult a Chicago professional for information about **Aircumulator Solo**—the Chicago single bar accumulator system. The Solo is designed to receive and accumulate flat items such as napkins, pillowcases or aprons onto **one** storage bar in each lane. Its extremely compact design and simplicity make it an excellent choice for many laundries processing napkins, pillowcases and similarly sized items.



**Aircumulator Solo**

## A Complete Range of Separating, Feeding, Ironing, Folding, and Sorting Options

Because Chicago specializes only in flatwork finishing equipment, it can offer the world's widest range of high production separating, feeding, ironing, folding, and sorting equipment. Complete flatwork finishing systems range from automated multi-roll systems producing over 2000 pounds per hour to compact ironers for small on-premise laundries.

Chicago's performance record is unmatched in thousands of installations in commercial, textile rental, institutional, and on-premise laundries. An experienced Chicago professional will be pleased to make an objective equipment recommendation based on your production, space, utility, and budget requirements.

Contact your local Chicago distributor or the factory sales assistance office for a no-obligation analysis of your needs.



**CHICAGO DRYER COMPANY**  
2200 North Pulaski Road  
Chicago, Illinois 60639-3737 USA

Phone • 773.235.4430  
Fax • 773.235.4439  
Web • www.chidry.com  
Email • chicago@chidry.com



5610 McAdam Road, Mississauga, Ontario L4Z 1P1  
905.890.1220 • 800.387.9503 • Fax: 905.890.7039  
email: harco@harco.com • www.harco.com