

WWW
ENERGENICS
.COM



WET TYPE
SERIES

AIRWASHER

THE SUPERIOR WATER SPRAY LINT COLLECTOR

CONTINUOUS CLEANING

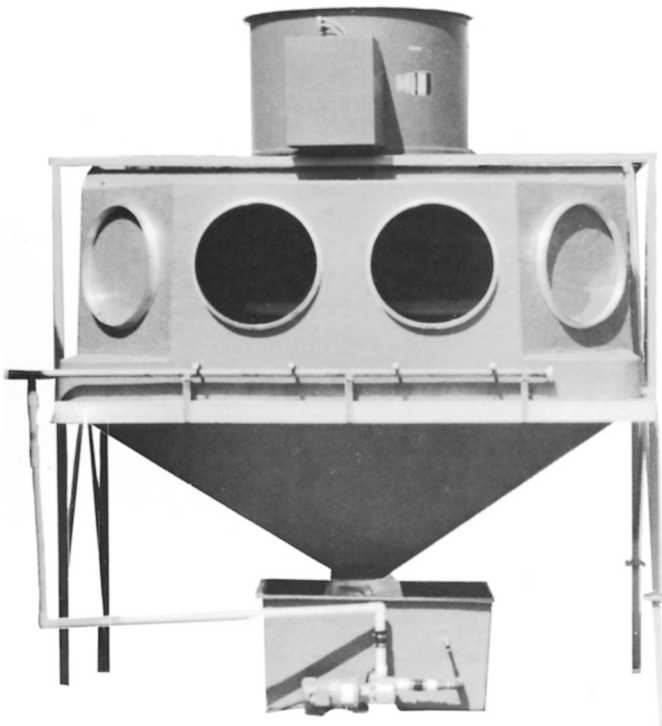

OPTIMUM WET FILTRATION

Better Filtration. AIRWASHER's Interated Target Spray uses no nozzles, creates a huge wall of water, filters excellently all the time.

Optimizes Dryer Performance.

Equipped with Energenics patented back pressure Controlled Variable Speed fan control, the exhaust fan will be adjusted to maintain dryer back pressure at the optimum dryer setting chosen by the dryer manufacturer. The system can be infinitely adjusted between dryer and exhaust fan operations.

Easier Operation. Either through our back pressure sensing VFD fan control or inter-connecting to the dryers, the Airwasher and dryers will operate simultaneously.

Selection. Horizontal or vertical mounted tubeaxial fan.

FIBERGLASS IS A SUPERIOR MATERIAL FOR WET FILTERING

Energenics blend of graphite impregnated fiberglass resin provides a corrosion proof, fire retardant, weather proof structure for the Airwasher. Fiberglass is ideally suited for this style filtration.

Ultra Smooth Surface.

The ultra smooth fiberglass interior significantly reduces the adherence of lint to the interior surface. This reduces the requirement for cleaning of the filter interior.

Resilient.

The laminate with a Flexural Strength of 36,900 psi will not crack like stainless steel.

Corrosion proof.

Entire structure is inert to organic solvents and weak acids.

Insulated.

Compared to "Black Fiberglass", steel transmits over 30 times as much heat to the occupied space.

Housing.

Energenics one and two piece construction allows for leak free operation.

Ask any user -

He will tell you his AIRWASHER is better built.

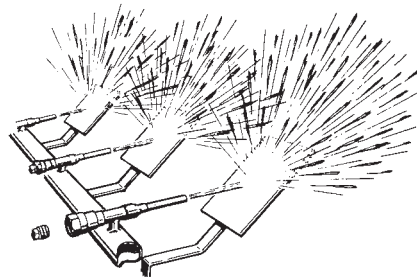

TARGET SPRAY SYSTEM

Energenics' Target Spray is completely accessible on the front of the AIRWASHER. Remove the plug at the rear of the spray pipe and you can see completely through. There are no obstructions to become fouled. Water delivered at a higher pressure through the spray pipe is blasted onto the fan-shaped target which diffuses it into tiny droplets.

SUPERIOR TO INSTALL

AIRWASHER is shipped fully assembled to save you the major cost of on-site assembly.

Rigid Frame.

Suspends the housing, isolates fan vibration, enameled tubular steel.

Custom Inlets.

You specify size and location. 45° offsets simplify exhaust piping.

Ask any user -

He will tell you his installation did cost less . . . and is far better.

MAJOR OPTIONS

Variable Speed Control Fan:

Utilizing a pressure transducer, measure the backpressure and adjust the fan to maintain a backpressure at the filter to be equal to the dryer manufacturers specification. The result is optimized drying performance.

Horizontal Fan Discharge:

Available for installations where height restrictions prevent the normal more efficient top mounted fan. The horizontal fan must be ducted upward later at some point and allow drainage back into the filter.

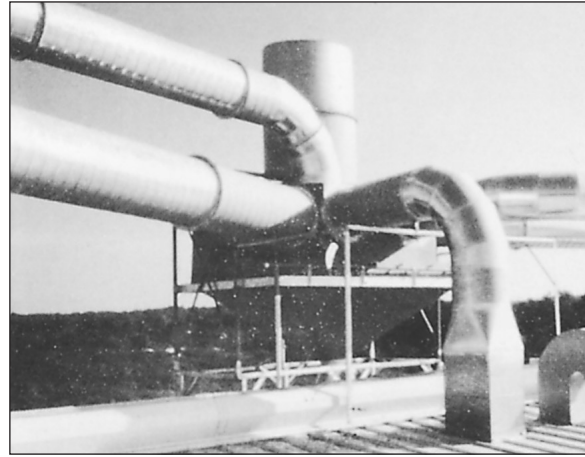

5-400 LB. DRYERS EXHAUSTING TO AIRWASHER - 40

INSTALLATION REQUIREMENTS

1. All Dryer exhaust ducts must be installed at a 5 degree angle, sloping down into the filter.
2. Ducts leading into the filter should be sealed so water drains back into the filter and does not leak onto the floor.
3. Horizontal fans exhaust a lot of water, ducts after the fan must be water tight.

SPECIFICATIONS: The dryers shall be equipped with a water spray lint collector with the following capacity, construction and accessories:

1. The collector shall have a capacity of _____cfm.
2. The collector housing shall be molded, seamless, corrosion resistant, fire-retardant fiberglass with a heat transfer coefficient of not more than 7 BTUH/FT²/°F.
3. The collector shall be fully assembled by the manufacturer.
4. The collector shall be equipped with a Tubeaxial exhaust fan with a capacity of _____cfm with _____" w.c. external static pressure.
5. The collector shall be equipped with a _____hp pump, _____gpm at _____ft head.
6. The collector shall be fitted with _____inlet collars of the dimensions and locations specified on approved drawings.
7. OPTION: the collector shall have a remote electrical control including the necessary motor starter wired to activate the collector when any one dryer is operated. This control shall shut off the lint collector fan should a fire signal be activated in any dryer.
8. OPTION: the collector control shall also include a Variable Speed Motor Controller to operate the Tubeaxial Fan at the correct speed to balance the exhaust of the dryers operating at any time.
9. OPTION: the collector shall be equipped with one or more Barometric Dampers to stabilize the negative pressure at the collector inlets regardless of the number of dryers operating.

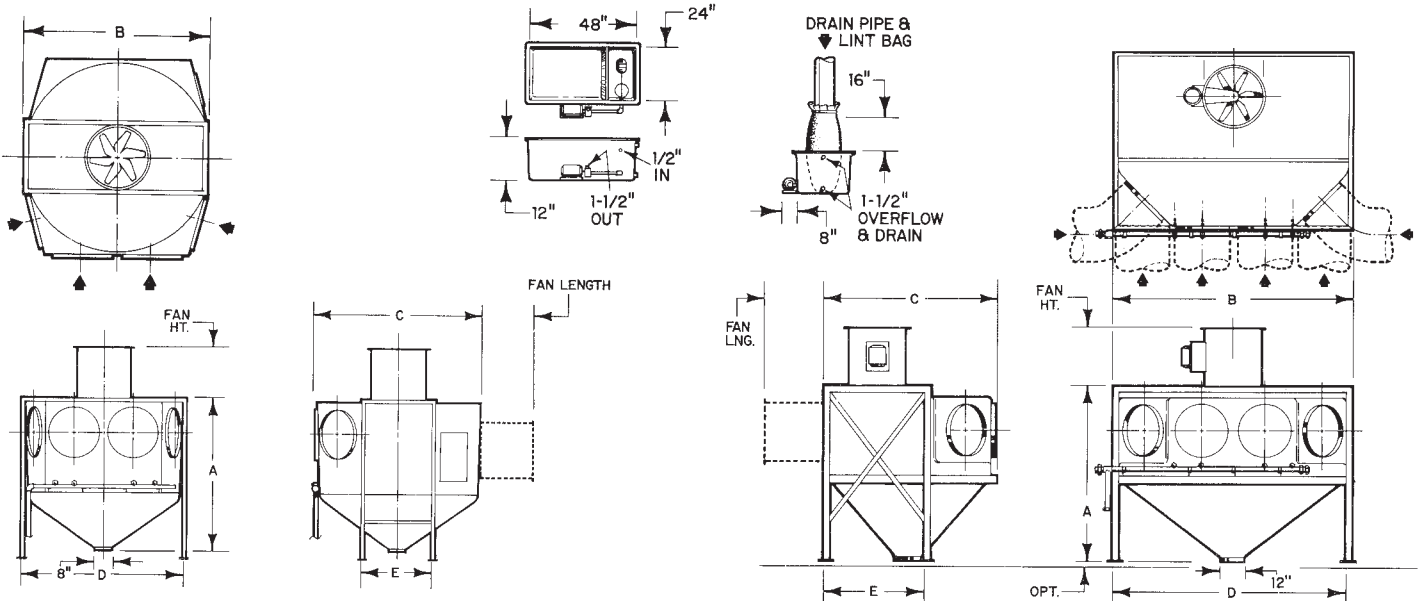

AIRWASHER 6

AIRWASHER 10-20

AIRWASHER 30-40

AIRWASHER	capacity-CFM	A	B	C	D	E	FAN HT-LN*	FAN HP*	PUMP HP*
8	8,000	72"	48"	78"	44"	42"	27"	1	1
10	10,000	86"	92"	96"	90 1/2"	38"	24"	2	2
20	20,000	86"	92"	96"	90 1/2"	38"	29"	5	2
30	30,000	93"	122"	90"	122"	53"	32"	10	2
40	40,000	93"	122"	90"	122"	53"	36"	10	2

*May vary with application



1470 Don Street • Naples, Florida 34104-3366
 Telephone: 941-643-1711
 Fax: 941-643-6081
 Customer Service: 800-944-1711
 www.energenics.com



5610 McAdam Road, Mississauga, Ontario L4Z 1P1
 905.890.1220 • 800.387.9503 • Fax: 905.890.7039
 email: harco@harcoco.com • www.harcoco.com