

## SPECIFICATIONS

# MLG35PD

MAYTAG® COMMERCIAL  
ENERGY ADVANTAGE™ MULTI-LOAD STACK DRYER



Shown in Stainless Steel.

### LEGENDARY MAYTAG DEPENDABILITY

Maximizing your equipment investment for over a half century.

### A COMPLETE LINE OF ENERGY-EFFICIENT SOLUTIONS

Maytag built the first appliance ever to receive the ENERGY STAR® label. Today we offer energy-saving laundry solutions for all commercial laundry needs—from energy-efficient dryers to highly efficient ENERGY STAR®-qualified washers—to help you save money and build profits.

### UPDATED CONTROLS

New soft-touch keypad for ease-of-use and durability.

### CAPACITY:

- 35 lb. Capacity
- 17% Greater Capacity Than a Maytag® 30-lb. Stack Dryer

### FOR YOUR CUSTOMERS:

- Fast-Drying Axial 100% Airflow System Enhances Airflow
- ThermoGuard™ System Helps Prevent Laundry Overheating
- Owner-Programmable Single-Phase Reversing
- Extra-Large Door Openings With Dual Pane Glass Door
- Time Remaining Digital Display
- Self-Diagnostic Microprocessor Controls

### FOR YOUR OPERATION:

- Low BTUs and Fast Dry
- Enhanced Insulation For Greater Efficiency
- Front Serviceable
- Single Payment System
- 2 Large-Capacity Lint Drawers

### BUILT-TO-LAST™ FEATURES:

- Heavy-Duty Enclosed Motors
- Fire Suppression System
- Four-Point Roller Support System
- 5 Year Limited Warranty—All Parts Covered

**AMERICA**  
AN AMERICAN COMPANY FOR OVER 100 YEARS

# SPECIFICATIONS



# MLG35PD

## MAYTAG® COMMERCIAL ENERGY ADVANTAGE™ MULTI-LOAD STACK DRYER

### MAYTAG® COMMERCIAL ENERGY ADVANTAGE™ MULTI-LOAD STACK DRYER MICROPROCESSOR COIN-DROP

DRYER SPECIFICATIONS	
<b>MODEL</b>	<b>MLG35PD</b>
<b>MOTOR</b>	
Single-phase, thermoprotected against overload, auto-reset	•
Drive Motor—HP (kw)	.25 (.19)
Blower Motor—HP (kw)	.50 (.37)
<b>CAPACITY</b>	
Lb. (kg) per drying chamber	2 x 35 (2 x 15.8)
Cu. ft. (cu. m) per drying chamber	2 x 12.27 (2 x .347)
<b>AIRFLOW</b>	
Cfm (cmm) per drying chamber	380 (10.76)
<b>TUMBLERS</b>	
Diameter—in. (mm)	2 x 30 (2 x 762)
Depth—in. (mm)	2 x 30 (2 x 762)
<b>ELECTRICAL REQUIREMENTS</b>	120V, 60 Hz
Export Models—options available	220-380V/1PH or 3 PH
<b>BREAKER/FUSE REQUIREMENTS</b>	
Amps per drying chamber	15
<b>EXHAUST DUCT DIAMETER</b>	
In. (mm)	2 x 6 (152)
<b>GAS RATING</b>	
BTU/hr. (kcal/hr.) per drying chamber	64,000 (16,138)
<b>GAS INLET</b>	
M.N.P.T. in. (mm)	2 inlets, 1/2 (12.7)
<b>COLORS</b>	
White	•
Stainless Steel	•
<b>APPROXIMATE WEIGHT</b>	
Crated—lb. (kg)	630 (286)
Uncrated—lb. (kg)	600 (272)
<b>DIMENSIONS</b>	
Height—in. (mm)	80 <sup>3</sup> / <sub>8</sub> " (2,042)
Width—in. (mm)	31 <sup>1</sup> / <sub>8</sub> " (791)
Depth—in. (mm)	39 <sup>5</sup> / <sub>8</sub> " (1,006)
Door opening diameter—in. (mm)	19 <sup>3</sup> / <sub>8</sub> " (492)
See specific instructions for proper installation. Because of continuous product improvement, Maytag reserves the right to change specifications without notice.	

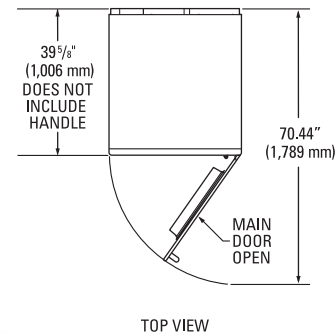
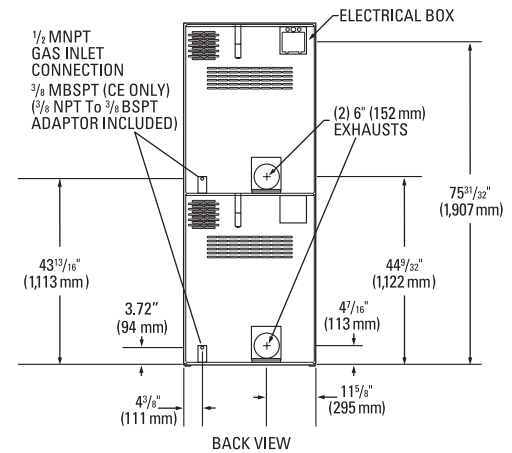
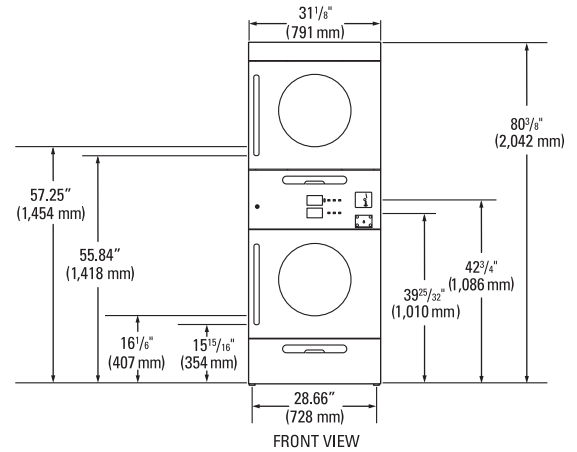

\*Visit [maytagcommerciallaundry.com](http://maytagcommerciallaundry.com) for complete warranty details.

5610 McAdam Road, Mississauga, Ontario L4Z 1P1  
 905.890.1220 • 800.387.9503 • Fax: 905.890.7039  
 email: [harco@harcoco.com](mailto:harco@harcoco.com) • [www.harcoco.com](http://www.harcoco.com)

®/™ ©2019 Maytag. All rights reserved.

MY190173 7/2019