

Chicago Breaks Through the Corner Barrier to Faster Production With the World's First Cornerless Feeding System

Anyone who has been in a laundry is familiar with the bottleneck in front of an ironer as laundry piles up waiting for operators to search for corners when loading linen into a spreader/feeder or directly into the ironer. Now you can slash operator handling time to less than half with the Edge™—the spreader/feeder from Chicago that offers performance and practicality. Even if you don't like spreader/feeders, you'll love the Edge because operators no longer have to search for those elusive corners—they merely "toss" any sheet edge onto its front conveyor to load it. The Edge does the rest.

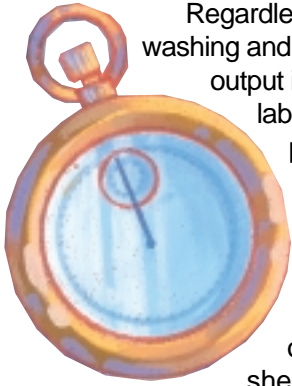

It's About Time



Regardless of the speed and automation of washing and folding equipment, finished linen output is always restricted by the most labor-intensive area of the production process: feeding the ironer. Until now, this has been the speed at which operators can search for and grasp one or two sheet corners before inserting sheets into a mechanical spreader/feeder or manually spreading and loading sheets directly into the ironer. Some feeding systems may claim to be "cornerless," but in fact require operators to find and carefully insert one edge *and one corner* into a large and mechanically complex machine for spreading and laydown—tasks which require more time, attention, and accuracy in loading. This is why Chicago decided you need the Edge.

Why The Edge Finishes First

Edge is the first spreader/feeder that electronically finds corners for operators and eliminates the need to carefully insert linen into clips, clamps, or multiple loading stations. The Edge is designed for sheets or table linen larger than 54" (1.4 m). It may also be used as the front end of a no-iron feeding/folding system for tumble dried blankets and other items.

Because the Edge electronically locates sheet corners for spreading, an operator only has to "toss" any sheet edge onto its input conveyor. The sheet does not have to be placed square, straight, or centered because Edge performs all of these tasks through a blend of CHI electronics and a remarkably simple method of letting the machine do more of the work for the operators. Spreading is performed by inverter-driven timing belt with microprocessor-controlled tensioning that gently stretches linen for a quality

laydown. Dual angle air pulses reliably deliver accurately fed sheets to the ironer or folder. Because operators are not wasting valuable time searching for corners, they can load up to twice as many pieces per hour.

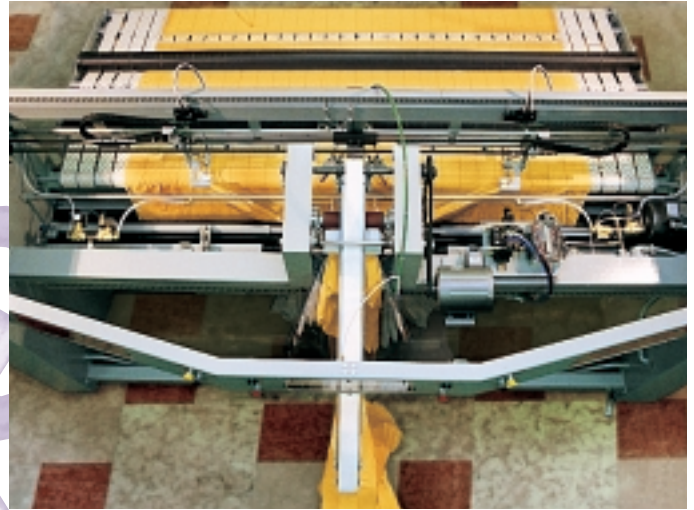

The ability to handle several pieces sequentially within the system at the same time and a maximum cycle rate in excess of 1200 per hour means that the Edge can deliver a consistently high volume of work to high speed ironers with fewer operators than any other feeding system.

Ergonomics—Automatic Feeding

Beyond maximizing productivity, Edge also makes the operators' job easier by requiring less concentration and fewer body motions during loading. The Edge requires no hand clipping and automatically advances linen when loaded, so operators do not have to raise their arms above shoulder height to carefully clip sheets or push a button to activate the feeding cycle. Over the course of a shift, operators perform simpler motions with less repetitive stress, while loading more pieces per hour than less ergonomically efficient methods.

Maximum operator throughput, simple electronic/mechanical systems, sensible erg

LOADING IS EASY AND FAST

because little skill
or concentration
is required



More Linen ... Less Labor

In every installation, the optimum number of operators and maximum pieces per hour depend on ironing speed, the condition of washed linen and operator routine. Edge's high speed feeding head accommodates multiple operators without extra feeding stations (and more mechanical components) for each operator. The result is fewer moving parts and a simpler electronic and mechanical system to maintain. Under many conditions, two persons will load the Edge in an alternating pattern. If sheets are overly tangled from washing or tumbling, a third person may help organize or load sheets to keep the ironer full at higher speeds. When the ironer is run at medium speed or sheets are laid out for high speed feeding, one person loading the Edge can keep the system full. Generally, a reduction of one to two FTE's can be achieved compared to traditional automated feeders and two or more FTE's can be saved compared to manual feeding.

Linen Vision—Stain/Tear Reject

For quality control, Edge's open design with clear acrylic panels allows operators to view pieces as they are being spread. Optional **Chicago Automatic Reject Processor** connects to a Chicago Skyline folder so that stained or torn items are separately discharged.

Buffer and Schedule Flexibility

When the ironer is being serviced or used for small pieces, a large quantity of sheets may be organized in carts as a "buffer" for feeding through the Edge by one person when the ironer becomes available.

CHI Makes It Smart

Chicago High Intelligence is the microprocessor control that directs all loading, spreading, feeding, and quality control functions. When an operator selects the type of item being processed, CHI automatically adjusts the Edge's conveyor and spreading speeds, item spacing, and linen stretch, as well as adjusting for thicker or thinner items. CHI also enables the Edge to be connected to a Chicago ironer and folder to form an integrated system in which speed changes, fold patterns, sorting, stacking, and operating status messages are automatically activated through the entire system as conditions warrant.

Reliability and Serviceability

Edge is engineered by the most experienced design team in the U.S. to ensure high productivity and dependability under tough laundry conditions. All components are manufactured to U.S. standards for prompt parts availability and compatibility with existing systems. By not relying on complex mechanical devices such as cables, servo motors, blades, or tamping bars, Edge's microprocessor-controlled timing belt spreading and dual angle air pulse laydown offer improved repeatability with fewer adjustments. Low profile design allows direct observation and access to all moving parts from floor level.



onomics, and a compact design with excellent serviceability give Chicago the Edge.

OPERATORS "TOSS"
linen onto a continuously
running conveyor that takes
linen in at speeds up to 400
FPM so operators can quickly
load the next piece



Dimensions and Utilities

Speed FPM (m/mm)	30–180 (8–45)
Motor HP (kw)	2.25 (1.7)
Air Inlet	1/2"
Air PSI (kPa)	85–120 (580–820)
Domestic Weight, lbs.(kg.)	3000 (1360)
Export Weight, lbs (kg.)	3300 (1500)

1. All utility connections are located at rear of machine unless otherwise noted.
2. Millimeter dimensions are in parenthesis.
3. Specifications are subject to change without notice. Consult factory for certified construction floor plan.

		HEIGHT	
E	ELECTRICAL CONNECTION AT REAR	32"	(815)
A	AIR CONNECTION 1/2" NPT AT REAR	13"	(330)

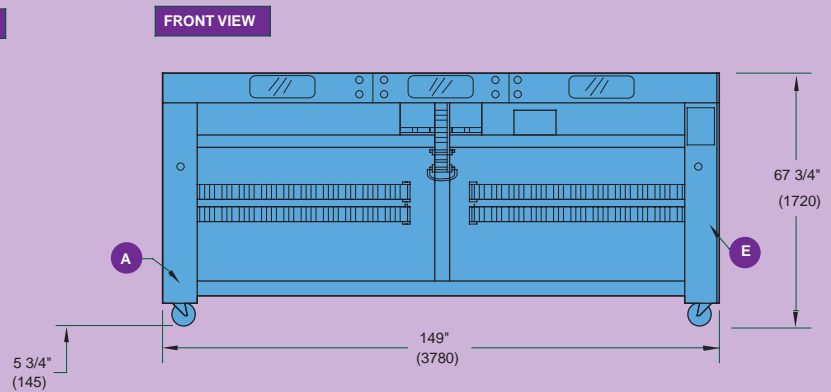
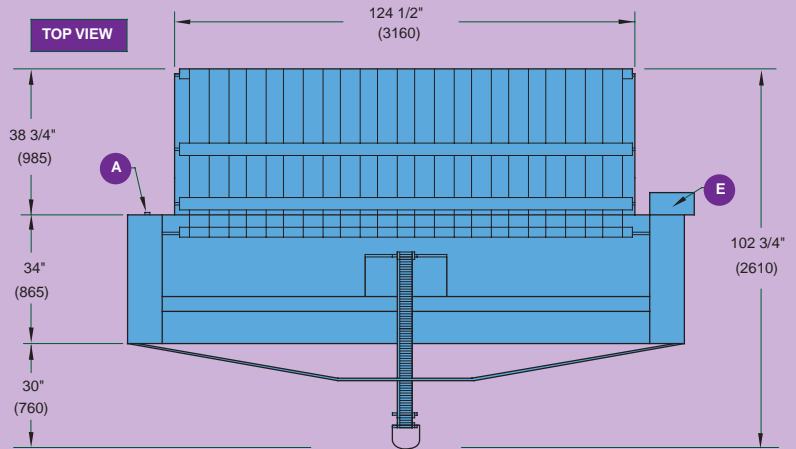
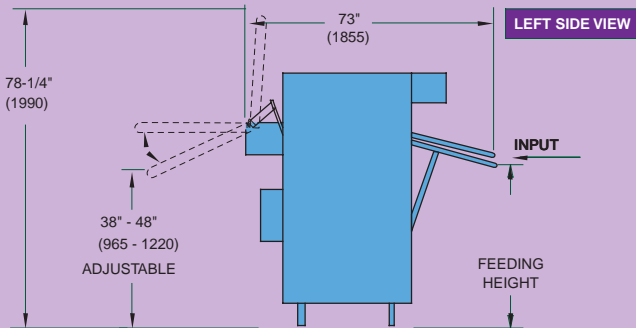

Conserves Floorspace

Edge's compact design allows operators to feed from the front of the ironer—without requiring a floor pit for larger items or space at either side. For direct ironer access for small piece feeding or waxing, a switch pneumatically raises Edge's rear conveyor out of the way. The Edge is caster mounted for mobility and the optional "Easi-Glide" track is available to electrically move the Edge an extra three feet away from the ironer, if desired.

Safety That Matches Efficiency

Electronic sensors automatically stop and raise Edge's input conveyor if an item that is too thick enters this area. CHI microprocessor also has anti-jam circuitry which automatically rejects misfed items without operator intervention before they become tangled in spreading belts. Interlocked end panels, 24 volt controls, stop buttons and bilingual/pictorial safety labels ensure that the Edge can be operated as safely as it is efficiently.

What's Behind the Edge

A sales and support team dedicated solely to flatwork finishing offers you a world of solutions from America's most complete line of flatwork finishing equipment, including the high production Century and Imperial ironer series, Skyline large piece and specialty folders, and Air Chicago—America's most popular towel, gown, and blanket folders. Contact a Chicago professional for a video and complimentary analysis of your finishing needs, including the Edge's impressive return on investment data.



CHICAGO DRYER COMPANY

2200 North Pulaski Road • Chicago, Illinois 60639
 Telephone (312) 235-4430 • Telefax (312) 235-4439

CHICAGO is a registered trademark of Chicago Dryer Company
 Bulletin #7435 U.S. and Foreign Patents Pending

Distributed by:

5610 McAdam Road, Mississauga, Ontario L4Z 1P1
 905.890.1220 • 800.387.9503 • Fax: 905.890.7039
 email: harco@harcoco.com • www.harcoco.com