

Spreader/Feeder

Flex~Feed

CHICAGO[®]



Two Station Loading Spreader/Feeder with Rapid Vac

Flex-Feed is a versatile, compact and fast two-station spreader feeder with a built-in vacuum laydown system for hand fed items. An especially versatile machine designed to process high quality tabletops and napkins, pillowcases and bed sheets—including difficult-to-handle fitted sheets.

In plants where quality is paramount while single lane feeding, the Flex-Feed allows operators to load flat sheets and tabletops into two separate loading stations for automatic spreading and feeding. Once pieces are fed and automatically spread, Chicago's exclusive baffled airfoil laydown system provides a neatly spread piece for a top quality presentation into the flatwork ironer

Flex-Feed

Dimensions and Utilities

CONNECTIONS	DIA.	HEIGHT
A Air Connection	1/2" NPT	82" [2082]
E Electrical Connection	--	9" [228]

NOTE:

1. Specifications subject to change without notice. Consult factory for certified construction floorplan.
2. Millimeter dimensions are in [].
3. All dimensions are +/- 1/2".
4. Utility connections are located as shown.

Top View

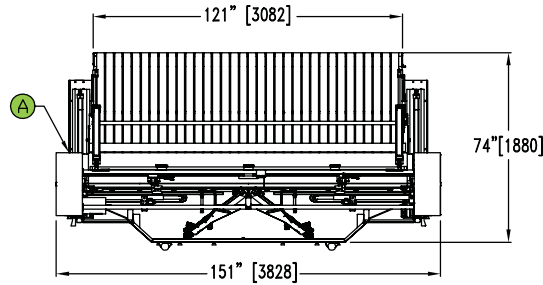

Front View

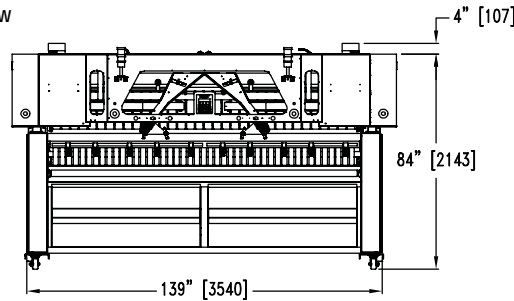

Left View

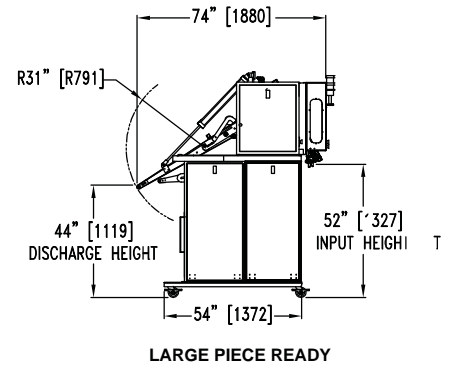

Right View

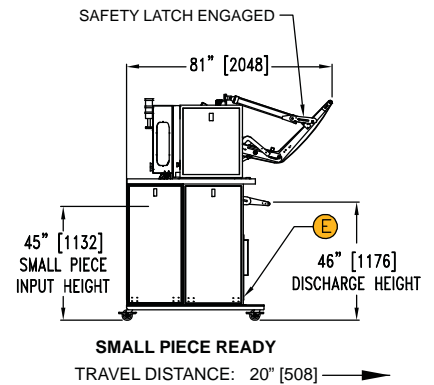

Features

Flex-Feed's built-in Rapid Vac direct feeding system is ideal for processing small pieces in one to five lanes (depending on piece size) – including pillowcases, napkins and larger goods such as round tablecloths. Operators are able to comfortably hand feed items directly onto the perforated feed conveyor. The specially designed vacuum field allows for exceptional quality on the leading and trailing edges, increased speed of handling, and a "vacuum grade" laydown into the flatwork ironer.



Small Piece Feeding Position

A Complete Range of Separating, Feeding, Ironing, Folding, and Sorting Options

Because Chicago specializes only in flatwork finishing equipment, it can offer the world's widest range of high production separating, feeding, ironing, folding, and sorting equipment. Complete flatwork finishing systems range from automated multi-roll systems producing over 2000 pounds per hour to compact ironers for small on-premise laundries.

Chicago's performance record is unmatched in thousands of installations in commercial, textile rental, institutional, and on-premise laundries. An experienced Chicago professional will be pleased to make an objective equipment recommendation based on your production, space, utility, and budget requirements.

Contact your local Chicago distributor or the factory sales assistance office for a no-obligation analysis of your needs.



CHICAGO DRYER COMPANY
2200 North Pulaski Road
Chicago, Illinois 60639-3737 USA

Phone • 773.235.4430
Fax • 773.235.4439
Web • www.chidry.com
Email • chicago@chidry.com



5610 McAdam Road, Mississauga, Ontario L4Z 1P1
905.890.1220 • 800.387.9503 • Fax: 905.890.7039
email: harco@harcoco.com • www.harcoco.com