

UNIPRESS

TUFR TENSIONING UTILITY FORM FINISHER WITH ROTATING FORM



Model TUFR

The TUFR produces top quality garments and is easy to operate. It features a One Touch control panel that makes it easy to choose from 9 available programs. Each program applies the correct amount of tension, steam and hot air to the garment for a high quality finish. This makes it simple to process a wide variety

of dry cleaned or wet cleaned garments. A rotating form allows the operator to position the rear clamps and use when required. The TUFR is equipped with a microprocessor with self-diagnostics and is built to exacting standards to provide years of trouble free service.

TUFR TECHNICAL DATA



5610 McAdam Road, Mississauga, Ontario L4Z 1P1
 905.890.1220 • 800.387.9503 • Fax: 905.890.7039
 email: harco@harcoco.com • www.harcoco.com

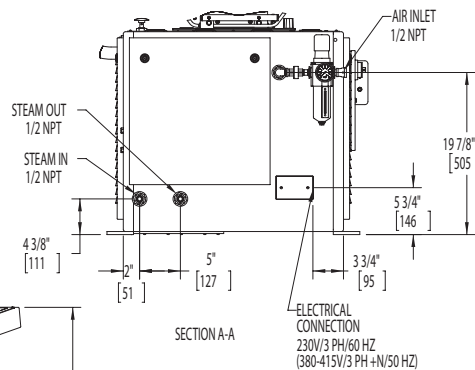
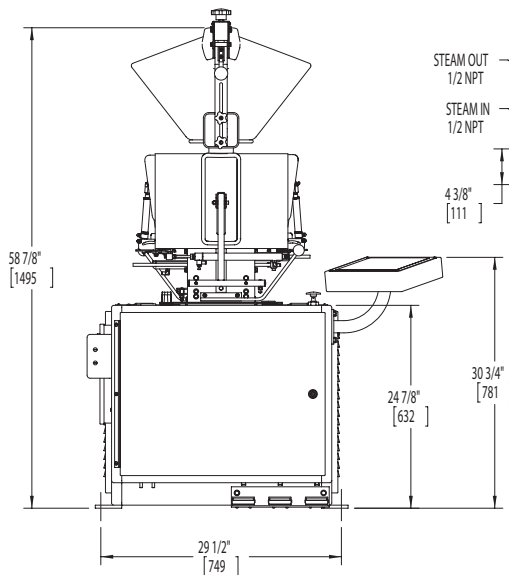
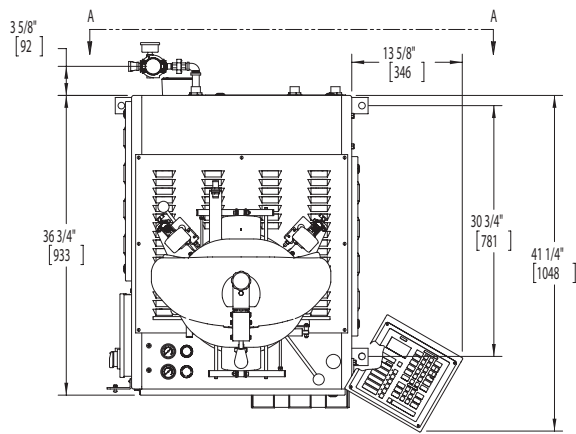

SPECIFICATIONS

	TUFR	
	SAE	Metric
Overall Height	58 7/8"	1495 mm
Overall Depth	41 1/4"	1048 mm
Overall Width	41 3/8"	1060 mm
Steam Inlet	1/2" NPT	1/2" NPT
Steam Outlet	1/2" NPT	1/2" NPT
Steam Supply	85 PSI	6 BAR
Boiler Horsepower	1-2 BHP	20-40 KG/H
Air Supply	85 PSI	6 BAR
Air Consumption	0.1 CU FT	2.8 liters/cycle
Electrical	230/3/60	380-415/3/50
Amperage	5.4 AMPS	1.1 Kw
Net Weight	466 lbs	211 kg

BUCK DIMENSIONS

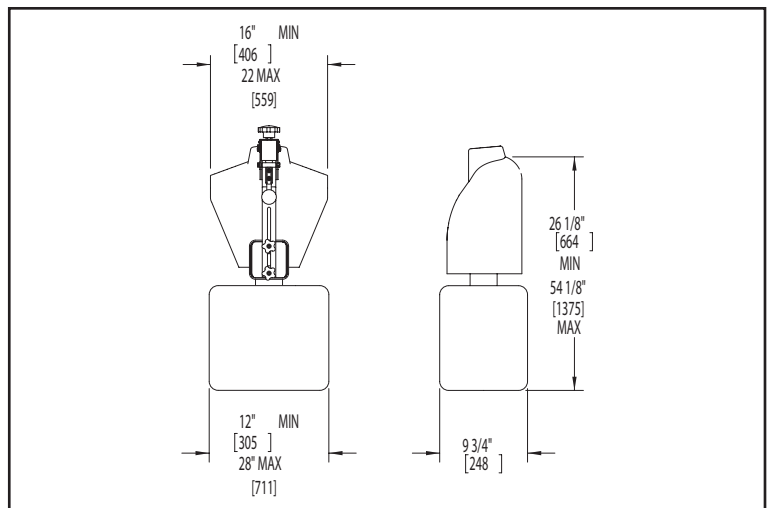

UNIPRESS

3501 Queen Palm Drive Tampa, Florida 33619
 Telephone (813) 623-3731 Fax (813) 626-2565
 www.unipresscorp.com