



# Commercial Super-Capacity Dryer

Non-Coin

With 100 years of experience in the industry and features that streamline service, Whirlpool® Commercial Laundry machines provide performance with the quality you expect.

## Commercial-Grade Features:

Choose a commercial-built product that withstands heavy traffic, regular use, and performs continuously.



### Galvanized, Heavy-Gauge Cabinet

Built from thick-gauge, high-quality steel, this cabinet handles high-traffic and constant use while offering top-caliber protection to the internal components.



### Four-Roller Suspension

Four heavy-duty rollers in the suspension are engineered to handle daily use and provide exceptional drying.



### Full-Wrap Console

The metal console wraps completely around the back of the machine, making it easy to clean, and offering optimal protection against unexpected liquid spills or vapor.



### 180° Wide-Opening Side-Swing Door

The side-swing door gives unhindered access for loading and unloading, while the 180° opening gives optimal flexibility in any space. Made from heavy, galvanized steel, it's designed for regular use.

## CEM2795FQ—27" Commercial Electric Dryer CGM2795FQ—27" Commercial Gas Dryer

- 7.4-cu.-ft. Capacity
- Galvanized, Heavy-Gauge Cabinet, Back, Side, and Front Panels
- 180° Wide-Opening Side-Swing Door

- 1/3-HP Motor
- 90-Day Labor/2-Year Limited Parts Only Warranty\*

\*See [whirlpoolcommerciallaundry.com](http://whirlpoolcommerciallaundry.com) for complete warranty details.

# Commercial Super-Capacity Dryer

## Non-Coin



### Dryer Specifications

Model	CEM2795FQ (Electric) CGM2795FQ (Gas)
Motor Size—HP (kw)	1/3 (.25)
Airflow (CFM)—CEM/CGM Model	178/183
Electric Heating Element (Watts) Domestic/Canada	5,600
Gas Rating—BTU/hr. (kcal/hr.)	22,000
Gas Inlet Size	3/8 N.P.T.
Capacity	
Cylinder volume—cu. ft. (liters)	7.4 (210)
Cylinder diameter—in. (mm)	26.26 (667)
Cylinder depth—in. (mm)	23.2 (590)
Dimensions	
Width—in. (mm)	27 (686)
Depth—in. (mm)	29.25 (743)
Height—in. (mm)	41 (1,042)
Door opening—in. (mm)	20.25 (514)
Exhaust duct diameter—in. (mm)	4 (101.6)
Crated Dimensions	
Width—in. (mm)	28.8 (731)
Depth—in. (mm)	30.8 (782)
Height—in. (mm)	44.65 (1,134)
Approximate Weight	
Uncrated—lbs. (kg) CEM/CGM model	115 (52.2)/120 (54.4)
Crated—lbs. (kg) CEM/CGM model	125 (56.7)/139 (59)
Electrical Requirements	
Electrical rating—voltage/HZ CEM/CGM Model	240V/60Hz/120V/60Hz
Breaker/Fuse—amps CEM/CGM Model	30/15
Warranty	2-Year Limited/90-Day Labor
Dimensions are for planning purposes only. See specific instructions for proper installation. Because of continuous product improvement, Maytag reserves the right to change specifications without notice.	

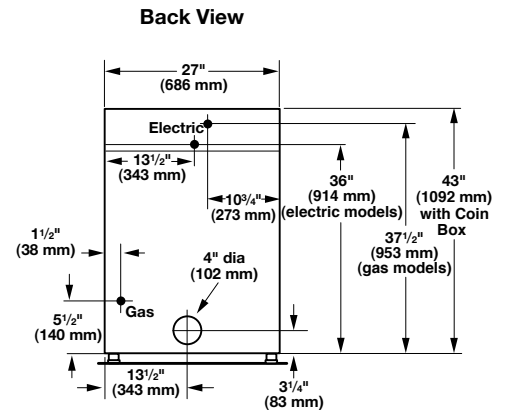
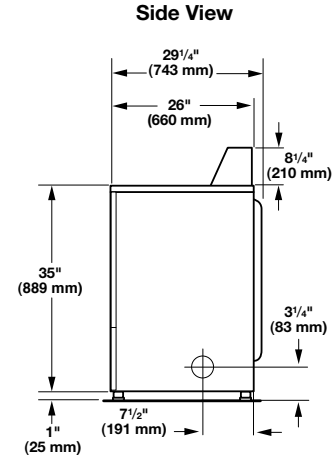

5610 McAdam Road, Mississauga, Ontario L4Z 1P1  
905.890.1220 • 800.387.9503 • Fax: 905.890.7039  
email: harco@harcoco.com • www.harcoco.com



### 2-YEAR LIMITED PARTS ONLY WARRANTY/90-DAY LABOR

For 90 days from the date of original purchase, when this commercial appliance is installed, maintained and operated according to instructions attached to or furnished with the product, Whirlpool Corporation (hereafter "Whirlpool") will pay for factory-specified replacement parts and repair labor to correct defects in materials or workmanship that existed when this commercial appliance was purchased. For the first two years from the date of purchase, when this major appliance is installed, maintained and operated according to the instructions attached to or furnished with the product, Whirlpool will pay for factory-specified replacement parts to correct defects in materials or workmanship that existed when this commercial appliance was purchased.