

One Piece Compact Ironer/Folder

Duo-Star™

CHICAGO®



Introducing

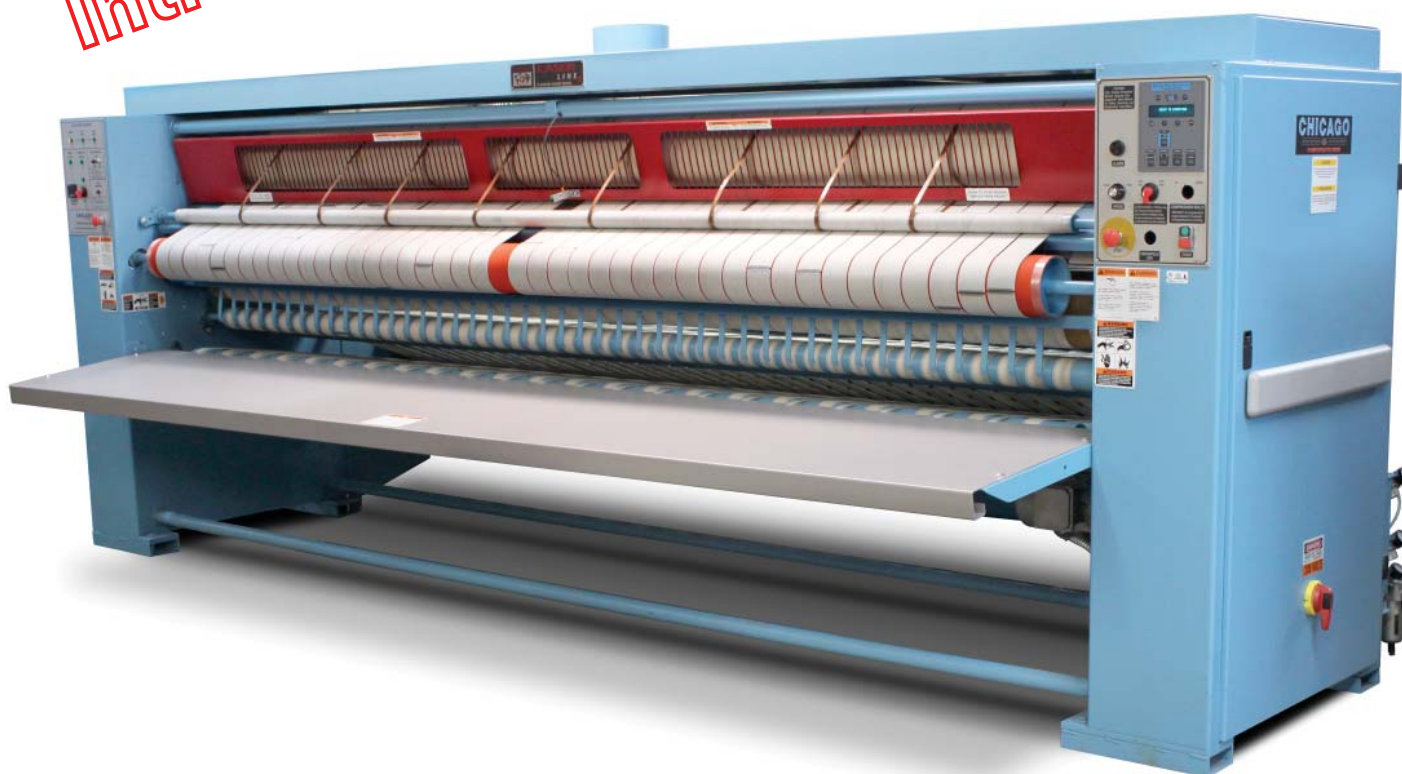

High Quality Ironing and Tri-Star Quality Air Pulse Folding in a New Compact Format

Now Chicago's powerful 20" (500mm) diameter roll ironers (with all the standard features of Chicago's Laser Series with up to twice the drying power of other ironers) are also offered with the high level accuracy and dependability of "Tri-Star" style primary folding in a brand new design. After drying and ironing, linen moves directly into the primary fold section where one or two primary folds are performed by timed air pulses. Four lane small piece folding is also an available option.

Available with either the classic CHI•Panel or Chicago's unique **CHI•Touch** PC-based touch screen control system. The advanced features of the CHI•Touch automatically selects the correct number of folds for all sizes of bed and table linen, eliminating the possibility of manual selection errors. If needs change, the auto mode can be changed to individual customized program settings or the Duo-Star can be operated in manual folding control mode. Operating, test, and diagnostic on-screen messages are in both text and graphical format for easy-to-understand operation.

Duo-Star

Dimensions and Utilities

NOTE:

1. Specifications subject to change without notice. Consult factory for certified construction floorplan.
2. Millimeter dimensions are in [].
3. All dimensions are +/- 1/2".
4. Utility connections are located as shown.

CONNECTION(S)	DIA.	HEIGHT
A Air Connection	1/2"	10" [254]
D Compressed Air Drain	1/4"	4" [102]
G Gas Connection	1"	34" [870]
E Electrical Connection	--	36" [914]

Top View

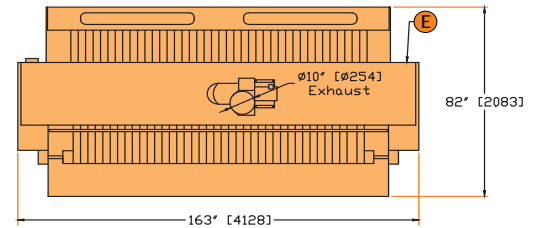

Side View

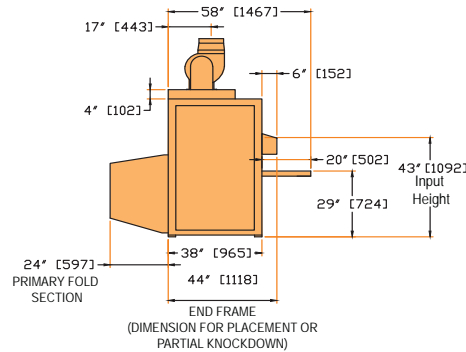

Front View

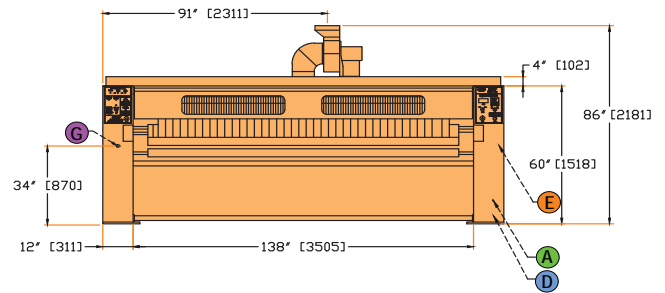

Features

Standard Features

- Mirror-finish ground and polished ironing cylinder with 120" (3050 mm) usable ironing width for even and efficient heat transfer
- Ironed and primary folded or bypassed (iron only) items are returned to front table for removal
- Touch control AC frequency inverter variable speed drive with soft start and jog features
- Heat-Lock system including exhaust canopy with insulated rear heat shield, two blowers and motors to remove excess moisture, raise ironing temperature, reduce energy consumption and improve laundry room comfort
- User-friendly controls with speed and temperature indicators to monitor ironing conditions and alert operators of situations requiring attention
- Compression rolls are pneumatically controlled for uniformed ironing and simplified operation
- Self-guiding tapes are used in feed area only. No tapes required in ironing area
- Environmentally-safe Nomex® high temperature ironing textiles for long service life and easy replacement
- Auto-tension return ribbons hold linen in firm contact with heated surface during ironing
- Jog forward-reverse and stain/tear reject (C.A.R.P.) which feed operators can use to direct stain/torn items to a separate destination for rewash or sewing
- Complete protection by safety covers, guards, stop buttons and bilingual safety labels
- Safety finger bar protects full width of ironer
- High efficiency power burner produces the maximum drying power available for faster evaporation of moisture from wet linen
- Eagle Eye™ electronic touchless ironing temperature sensor assures pinpoint temperature control without need for mechanical contact shoe

A Complete Range of Separating, Feeding, Ironing, Folding, and Sorting Options

Because Chicago specializes only in flatwork finishing equipment, it can offer the world's widest range of high production separating, feeding, ironing, folding and sorting equipment. Complete flatwork finishing systems range from automated multi-roll systems producing over 2000 pounds per hour, to compact ironers for small on-premise laundries.

Chicago's performance record is unmatched in thousands of installations in commercial, hospitality, health care, textile rental, institutional and on-premise laundries all over the world. An experienced Chicago professional will be pleased to make an objective

equipment recommendation based on your production, space, utility and budget requirements. Contact your local Chicago distributor or the factory sales assistance office for a no-obligation analysis of your needs.

Chicago's Customer Service department offers full technical and service support by telephone and on our website. We also offer overnight service for quick parts availability. Visit our website, www.chidry.com, to learn more about our complete line of flatwork finishing systems, including video of Chicago® equipment in action.



CHICAGO DRYER COMPANY
2200 North Pulaski Road
Chicago, Illinois 60639-3737 USA

Phone • 773.235.4430
Fax • 773.235.4439
Web • www.chidry.com
Email • chicago@chidry.com



5610 McAdam Road, Mississauga, Ontario L4Z 1P1
905.890.1220 • 800.387.9503 • Fax: 905.890.7039
email: harco@harcoco.com • www.harcoco.com